



because clean matters.



Ultrasonic Cleaning System Tabletop & Recessed Models

Owner/Operator Manual



L&R Manufacturing Company
577 Elm Street, PO Box 607
Kearny, NJ 07032-0607 USA
Tel: 201.991.5330 Fax: 201.991.5870

www.LRultrasonics.com
info@LRultrasonics.com

Table of Contents

	<u>Page</u>
Safety Precautions	3
Chemicals Harmful to Your Ultrasonic Cleaner.....	4
What is Ultrasonic Cleaning?	5
Ultrasonic Cleaner Specifications.....	6
Unpack, Set-up, and Start-Up	9
Cleaning Methods	16
Popular Accessories.....	18
Ultrasonic Cleaning Solutions	19
Trouble Shooting	22
Foil Test.....	23
Service Center Locations	24

Warning

Safety Precautions and Warnings

Before using your Ultrasonic Cleaner, please read and thoroughly understand these safety precautions. Failure to comply with these warnings and safety precautions may result in serious personal injury or property damage.

To avoid electrical shock:

- Unplug your machine from the power source before filling or emptying the tank.
- Keep the area around the ultrasonic cleaning machine clean and dry. Water and high voltage can cause electric shock.
- Ensure that the ultrasonic cleaning machine is properly grounded. Do not remove the grounding prong on the line cord plug.
- Do not immerse your ultrasonic cleaning machine in water.
- Do not disassemble your ultrasonic cleaning machine—hazardous voltages inside the tank are dangerous.

- **Warning:** Unplug the machine before moving it.
- **Warning:** Do not ever use alcohol, gasoline or flammable solutions. Doing so could cause a fire or explosion.
- **Warning:** Do not immerse the ultrasonic cleaning machine in water or any other liquid. To maintain the tank free of sediment and soap scum: Unplug, Rinse and Wipe Dry.

CAUTIONS:

- Do not use acids or bleach. These materials can damage the ultrasonic cleaning tank.
- Use only L&R solutions for best results. CHANGE THE ULTRASONIC CLEANING SOLUTION DAILY OR AS NEEDED.
- Do not allow the solution to drop below the operating level of the tank while the ultrasonic cleaning machine is in operation.
- Never run the ultrasonic cleaning machine at solution temperatures over 160°F, 71°C.
- Do not place parts or containers directly on the bottom of the ultrasonic cleaning tank.
- When using beakers or an auxiliary pan, enough solution must be in the tank to act as a coupling agent. The beakers should be suspended below the solution level, but above the bottom of the tank.
- Do not leave the instruments in the ultrasonic cleaning machine overnight; it may cause corrosion (to the instruments). All instruments must be rinsed and dried before using.
- Avoid operating the ultrasonic cleaning machine in extremely dusty areas.
- Keep the ventilating louvers clean and free of obstructions.
- Do not disassemble your machine. Contact your dealer.

**FAILURE TO COMPLY WITH THESE WARNINGS AND PRECAUTIONS
WILL VOID YOUR WARRANTY.**

Chemicals Harmful To Your Ultrasonic Cleaner

Acetophenone	Ferric Chloride
Aluminum Chloride	Ferrous Chloride
Aluminum Fluoride	Ferris Sulfate
Aluminum Sulphate	Fluoboric Acid
Ammonium Bifluoride	Fluorine
Ammonium Chloride	Hydrobromic Acid
Ammonium Hydroxide	Hydrochloric Acid
Amyl Chloride	Hydrogen Peroxide
Antimony Trichloride	Hydrocyanic Acid
Aqua Regia	Hydrofluoric Acid
Benzethonium Chloride	Hydrofluosilicic Acid
Bromine	Iodoform
Calcium Bisulfate	Mercuric Chloride
Calcium Bisulfite	Muriatic Acid
Calcium Hypochloride	Nitric Acid
Chloracetic Acid	Phosphoric (crude)
Chloric Acid	Sodium Hypochlorite
Chlorine, Anhydrous	Potassium Chloride
Chromic Acid	Stannic Chloride
Chlorine Bleach	Stannous Chloride
Citric Acid	Sulfur Chloride
Copper Chloride	Sulfuric Acid
Copper Fluoborate	Zinc Chloride
Ethyl Chloride	

The use of these chemicals will damage your machine
and void the warranty.

Congratulations on your purchase of an L&R Ultrasonic Cleaning System. Your machine is part of a complete cleaning process which is thoroughly described in this owner/operator manual.

What is Ultrasonic Cleaning?

Ultrasonic cleaning is created by sound waves that are transmitted at frequencies beyond the range of human hearing. A generator located within your system develops the high frequency power which causes a transducer to radiate and produce the sound waves.

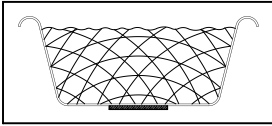

Sound waves are carried through the solution in the tank and create a unique vibrational pattern causing alternating high and low pressures in the liquid.

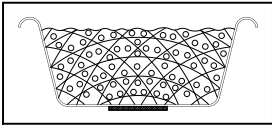

During the low pressure stage, millions of tiny bubbles form. This process is called CAVITATION, meaning the formation of cavities.

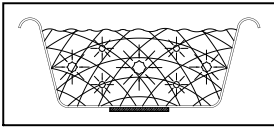

During the high pressure stage, the bubbles collapse or implode, releasing enormous amounts of energy. Working in all directions, the bubbles attack every surface and invade all recesses and crevices, pulling debris off the object being cleaned.

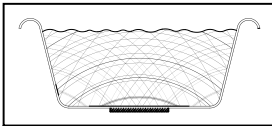

SweepZone Technology® enhances the ultrasonic activity by automatically changing frequencies, thus creating a cleaning grid which literally sweeps through the tank. A more uniform cleaning pattern and significantly shorter cleaning times result when “hot spots” present in traditional ultrasonics are eliminated.

Equally important to efficient cleaning is selecting a proper solution for the cleaning task. See page 18 of this manual for cleaning applications and solutions.

Quantrex® Models

Model	Description All Units Include cover	Input Power Average Watts 117 VAC 60 Hz	Output frequency	Overall Dimensions Inches & Centimeters L x W x H	Shipping Weight Lbs. & Kgs. (Approx.)	Tank Capacity Gallons & Liters	Tank Internal Dimensions Inches & Centimeters L x W x D
Q90	Timer standard	55	43 KHz	7.0 x 6.38 x 8.75	8	0.50	5.88 x 5.38 x 4.0
	Heater optional	110 w/heat		17.8 x 16.2 x 22.2	3.63	1.9	14.9 x 13.7 x 10.2
Q140	Timer, drain standard	95	43 KHz	10.25 x 6.5 x 8.25	10	0.85	9.38 x 5.38 x 4.0
	Heater optional	150 w/heat		26.0 x 16.5 x 21.0	4.3	3.2	23.8 x 13.7 x 10.2
Q210	Timer, drain standard	135	43 KHz	12.75 x 7.0 x 11.0	14	1.56	11.75 x 6.0 x 6.0
	Heater optional	335 w/heat		32.4 x 17.8 x 27.9	6.36	5.7	29.8 x 15.2 x 15.2
Q310	Timer, drain standard	320	43 KHz	16.5 x 10.0 x 12.13	26	3.25	15.5 x 9.0 x 6.0
	Heater optional	520 w/heat		41.9 x 25.4 x 30.8	11.7	12.3	39.4 x 22.9 x 15.2
Q360	Timer, drain standard	240	43 KHz	12.75 x 10.5 x 14.25	22	3.63	11.5 x 9.25 x 8.0
	Heater optional	440 w/heat		32.4 x 26.7 x 36.2	9.9	13.6	29.2 x 23.5 x 20.3
Q650	Timer, drain standard	415	43 KHz	21.75 x 13.75 x 12.7	33	6.30	19.75 x 11.75 x 6.5
	Heater optional	815 w/heat		55.2 x 34.93 x 32.3	15	24.6	50.2 x 29.8 x 16.5

PC3® Model

Model	Description All Units Include cover	Input Power Average Watts 117 VAC 60 Hz	Output frequency	Overall Dimensions Inches & Centimeters L x W x H	Shipping Weight Lbs. & Kgs. (Approx.)	Tank Capacity Gallons & Liters	Tank Internal Dimensions Inches & Centimeters L x W x D
PC3	Self-contained, high performance unit	22	55 KHz	5.38 x 4.13 x 5.0	4	0.14	4.75 x 3.38 x 2.63
				12.7 x 10.2 x 12.7	1.8	0.53	12.1 x 8.6 x 6.6

SweepZone® Models

Model	Description All Units Include cover	Input Power Average Watts 117 VAC 60 Hz	Output nominal frequency sweep range Sweep rate	Overall Dimensions Inches & Centimeters L x W x H	Shipping Weight Lbs. & Kgs. (Approx.)	Tank Capacity Gallons & Liters	Tank Internal Dimensions Inches & Centimeters L x W x D
S200	Timer, drain standard	95	45 KHz	12.68 x 6.88 x 8.75	12	1.13	11.75 x 6 x 4
	Heater optional	165 w/ heat	+/- 2KHz 3Hz	32.1 x 17.4 x 22.2	5.5	4	29.8 x 15.2 x 10.2
S310	Timer, drain standard	400	43 KHz	16.5 x 10 x 12	26	3.25	15.5 x 9 x 6
	Heater optional	600 w/ heat	+/-2KHz 83Hz	41.9 x 25.4 x 30.5	11.7	12.3	39.4 x 22.9 x 15.2
S1000	Timer, drain	500	44 KHz	19 x 17 x 20	101	10.00	16 x 14 x 10.5
	standard	1445 w/ Heat	+/-1.5KHz 83Hz	48.3 x 43.2 x 50.8	45.6	44	40.6 x 36.6 x 26.7

SweepZone[®] Recessed Units

Model	Description All Units Include cover	Input Power Average Watts 117 VAC 60 Hz	Output nominal frequency sweep range Sweep rate	Overall Dimensions Inches & Centimeters L x W x H	Shipping Weight Lbs. & Kgs. (Approx.)	Tank Capacity Gallons & Liters	Tank Internal Dimensions Inches & Centimeters L x W x D
310R	Timer, drain standard	400	43 KHz	Generator	26	3.25	15.5 x 9 x 6
			+/-2KHz	16.25 x 10.13 x 6.25	11.7	12.3	39.4 x 22.9 x 15.2
			83Hz	41.3 x 25.7 x 15.9			
360R	Timer, drain standard	300	43 KHz	Generator	22	3.63	11.5 x 9.25 x 8
			+/-2KHz	16.25 x 10.13 x 6.25	9.9	13.6	29.2 x 23.5 x 20.3
			83Hz	41.3 x 25.7 x 15.9			
650R	Timer, drain standard	500	43 KHz	Generator	38	6.50	19.75 x 11.75 x 6.5
			+/-2KHz	16.25 x 10.13 x 6.25	17.2	24.6	50.2 x 29.8 x 16.5
			83Hz	41.3 x 25.7 x 15.9			

ENVIRONMENTAL: For Indoor Use Only. Allow 2" or more behind unit for air flow. Locate unit in a dry place, 0-35° C, RH 96% Non-Condensing non-corrosive atmosphere below 2000M altitude. Position the unit to allow disconnecting the AC plug.

RECESSED SYSTEM: A Remote Timer is provided with the Recessed System. The Outlet on the Remote Timer is for use with the Recessed System Remote Generator ONLY! This Outlet is marked " Remote Generator Only ".

Unpack, Set-Up and Start-Up

Unpack

- Remove your ultrasonic cleaner from its shipping container and inspect it for any possible damage which may have occurred during shipping. (Claims for shipping damage should be made immediately against the carrier.)
- Check the serial number of your machine with the serial number on the shipping carton. If they are not the same, contact your dealer or the factory.
- Complete the warranty card and mail it to L&R Mfg. Co. or visit www.LRultrasonics.com to register.

Set-Up

Table Top Machines

- Select your desired location for the cleaner. It should be in close proximity to a sink or waste lines to facilitate ease of draining. A drain assembly, supplied with the cleaners having drains, will allow you to place the unit on either side of the sink or to connect it directly into a waste line. Provide at least two inches all around the machine to allow for adequate cooling.

Directions for Attaching Pre-Assembled Drain Hose

for 140, 200 and 210 models

1. Open bag and remove pre-assembled drain hose.
2. Loosen large black nut on the elbow (drain fitting) at end of the drain hose by turning 2 – 3 complete revolutions. (Be Careful: Excessive turns will result in the black nut falling off and the elbow coming apart.)

3. Turn the ultrasonic machine so the back of the unit is facing you. Locate the metal drain tube coming out of the machine. Slide the elbow (drain fitting) over the metal drain tube until elbow is almost flush with back of machine. (Note: Sliding the elbow will require some force and it is recommended to place one hand on the front of the machine for stability.)

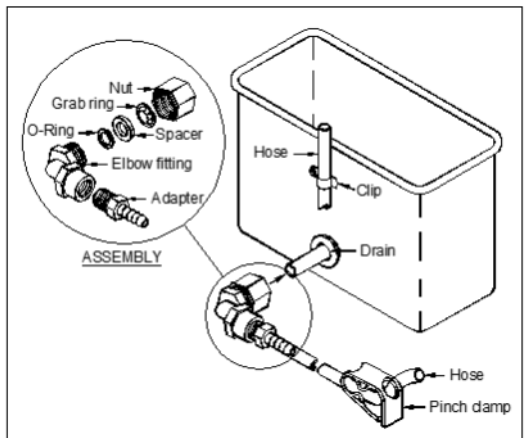

4. To tighten elbow (drain fitting), turn the black nut counter-clockwise while holding the elbow in place. (Be careful not to over-tighten the black nut.)
5. Close drain hose by pressing down on pinch clamp until secure (approximately 4 “clicks”).
6. Secure end of plastic tubing into clip at top of machine.

Attaching the Drain Assembly for 310 and 650 models

- Pick up drain assembly supplied and loosen nut on elbow.
- Position machine so that you are facing the drain tube.
- Carefully slide the assembly over the drain tube.
- Adjust the position of the drain tube as desired. (Drain right, left or down.)
- Hand tighten nut. Do not over-tighten. If further tightening is needed an adjustable or a 1 inch open-ended wrench is recommended.

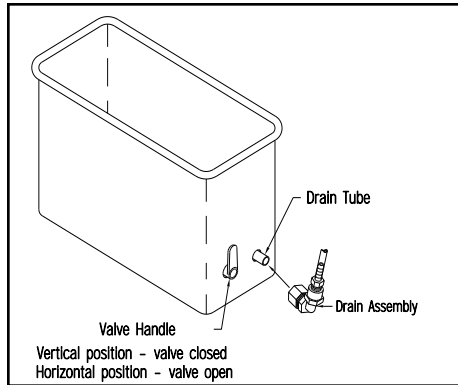

Recessed Machines

Installing the Tank in Your Countertop

Your recessed ultrasonic cleaner is designed to be a permanent installation into a countertop in your office or shop. It is recommended that the stainless steel mounting rim supplied with the cleaner be installed between the rim of the tank and the countertop to ensure a good, watertight seal at the countertop. A cable or cables (depending on the model) will connect the tank to the generator.

1. Select your desired location for the tank on your countertop. Close proximity to a sink is desirable for ease of drain connections.
 - a. Make sure there are no drawers below your selected position on the countertop and that there are doors which allow easy access to the drain valve on the tank.
 - b. If the cable(s) interconnecting the tank and generator can not be routed behind the countertop, a separate hole will have to be drilled in the countertop to accommodate them.

2. Included with your recessed cleaner is a stainless steel mounting rim. Use it as a template and trace the required cut out on your countertop with a crayon or china marker.
3. Drill a $\frac{1}{2}$ inch hole anywhere within the section to be cutout.
4. Using a sabre saw, carefully cut the tank shape out of the countertop.
5. Clean away saw dust. Position the mounting rim over the cut out and check fit. Adjust hole if required.
6. Remove rim. Carefully apply a bead of clear silicone (GE 732 or equivalent) $\frac{1}{2}$ inch wide, $\frac{1}{8}$ inch high around the cut out.

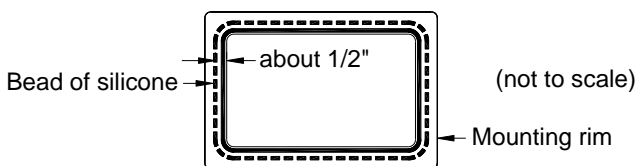

7. Position mounting rim over cut out.
8. Carefully apply a bead of silicone $\frac{3}{8}$ inch wide, $\frac{1}{8}$ inch high around the inside edge of the mounting rim.
9. Set the tank into the rim. Allow the silicone to squeeze out. Wipe the excess silicone.
10. Allow the tank to set for at least eight hours without being disturbed.
11. After the silicone has cured, carefully scrape any excess silicone, being careful not to scratch the rim or countertop.

Recessed rim option

Recessed rim installation is similar. For specific details check instructions supplied with that option.

Connecting the Drain

Protruding through the bottom of the tank assembly on a recessed machine is a drain valve and associated fittings and a 36" length of tygon tubing.

Every recessed installation is unique because of different counter sizes, access to waste lines, etc., and should be done by a plumber or technician in accordance with local plumbing codes.

If a sink and sink drain are near the location the recessed cleaner is to be installed, we recommend changing the sink's tailpiece to a "dishwasher tailpiece". Then, using an appropriate combination of adapters/fittings, the drain tubing can be connected to the tailpiece. See sketch.

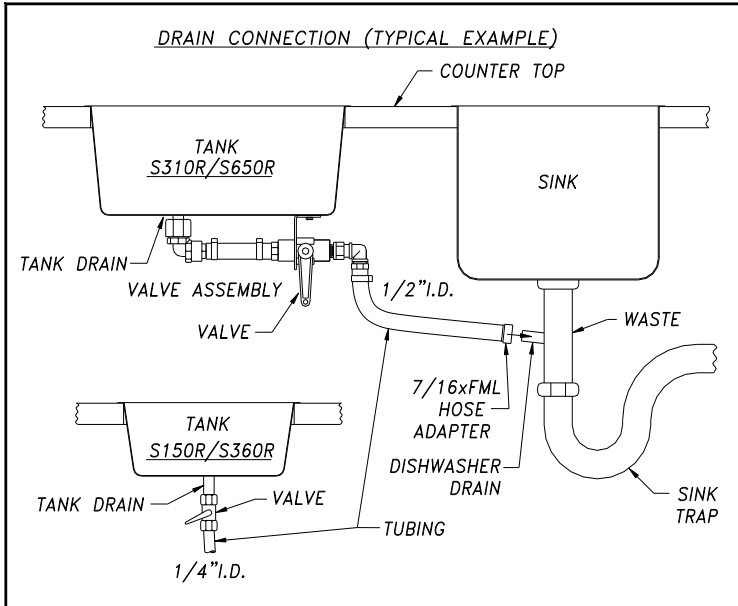

Interconnecting The Tank and Generator

- S150R—Connect the coaxial cable from the tank into the R.F. connector on the rear of the generator (Turn Clockwise to lock connector).
- S310R, S360R, S650R—Connect the coaxial cable from the tank into the R.F. connector on the rear of the generator (Turn Clockwise to lock connector) and the thermo probe cable into the 3 pin connector on the rear of the generator.
- Connect the green/yellow wire from the tank to an appropriate earth ground such as a cold water supply pipe using a grounding clamp or similar approved grounding device.

Do not attempt to connect or disconnect any cables with the generator plugged in. Connect the generator plug last.

Start Up

STEP	ACTION
1	Select the proper L&R Cleaning Solution.
2	Dilute with warm tap water as specified and fill one half to two-thirds of the tank.
3	Add parts to be cleaned. Use a basket or other accessory which keeps material off the bottom of the tank. If necessary, add more solution to bring the level to about 1 inch from the top of the tank.
4	Plug the cleaner's line cord into a grounded outlet.
5	<p>To activate your machine, simply set your timer (on mechanical timers turn knob clockwise) to the number of minutes desired for cleaning. These self-timing units will automatically shut themselves off at the end of the cycle.</p> <p>For recessed installations with an optional remote timer... connect the machine's power cord to the outlet on the rear of the remote timer and connect the remote timer's power cord to a grounded outlet. Set the machine's timer to the "HOLD" position. Then set the timer on the remote to the number of minutes desired for cleaning.</p>

NOTE: If this is the first time you are running the cleaner or you have changed the cleaning solution, you must degas the solution. Fresh solutions contain many dissolved gasses which reduce effective ultrasonic action. Although solutions will naturally degas over time, operating the machine for five to ten minutes before using it to clean will accelerate the degas process.

Digital Timer

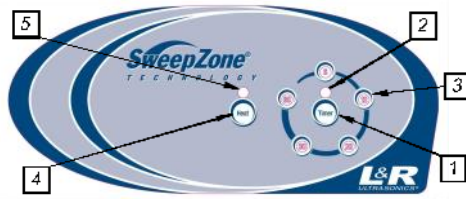

The L&R Digital timer controls the operation of the Ultrasonic cleaning machine and its options. There are three sections of control; Main Power, Timer, Heat.

The Main power on / off switch: Located on the rear panel of the machine near the line cord and fuse holder. This switch controls the main power to the unit. When this switch is in the on position it is illuminated and the yellow standby light, on the front panel, is lit (item 2).

Timer Section: The timer section controls the Ultrasonic operation of the machine. There are five different selectable predefined timer settings (6, 12, 20, 30, 60 minutes). The timer set button (Item 1) is in the center of the time selection indicator lights (Item 3) just below the yellow standby indicator light (Item 2).

Pressing the timer button once, when the unit is in standby mode will start the ultrasonic cleaner and select an operating time of 6 minutes. If the timer button is pressed again a second time then the 12 minute indicator will light and the unit will then run for 12 minutes and turn off when done. If the timer button is pressed while the machine is operating the next time interval is selected and the machine will continue to operate until the end of this preset time. Pressing the timer button will increment the time interval from 6 to 12 to 30 to 60 and then to Standby (off). The time indicator light remains lit until the end of the cycle.

Optional Heater Section: The heater section has the heater push button (Item 4) and a Red indicator light (Item 5). The light is active when the heater circuit is energized. The heat remains on until the button is pressed again and the indicator light goes off. If the unit has not had any buttons pressed for 2 hours the heat turns off as a safety precaution. **Heat should not be left on unattended.** The operator should not rely on this automatic feature to turn the heat function off automatically - this feature is for safety only.

The main power switch is intended to be turned off when the machine is not in use. None of the digital timer functions will work if the main power switch is in the off position.

Mechanical Timer

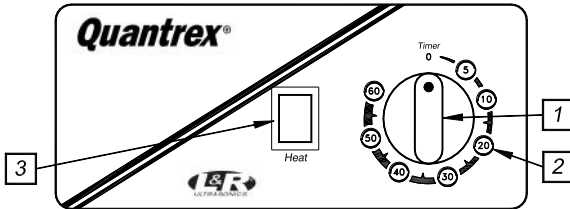

START-UP

1. To start your machine set your timer (item 1) to the pre-set time (item 2) desired for ultrasonic cleaning. The machine will automatically shut itself off at the end of the pre-set time.
2. Machines equipped with heat have a separate “On-Off” rocker switch (item 3) located on the front panel. Pushing this switch to the “On” position allows pre-heating of cleaning solution prior to turning on the machine. **The rocker switch is lit when the heater is on and must be pushed to the “Off” position when the heater is not in use.**
3. The heater is designed to maintain the temperature of the cleaning solution between 125°-150°F (52°– 65°C°). When you operate both the ultrasonics and heat simultaneously with the tank covered for an extended period of time, the solution temperature will rise above this level. At this point, the thermostat will automatically shut the heater element off until the solution drops below maximum heat level. The thermostat will be re-activate as required. During this cycle, the heat indicator light will remain lit. Because of the intense ultrasonic power dissipated in the form of heat, the temperature of the solution may once again rise above 150°F with the ultrasonics operating. **The heat rocker switch must always be turned off manually. This switch does not turn off automatically.**

Cleaning Methods

Direct Method

In this method, the part(s) to be cleaned are placed in your accessory basket. The basket is then placed directly into the main tank already containing the proper L&R cleaning solution.

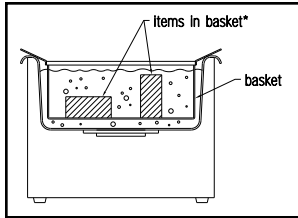

Cleaning times may vary depending on the amount and types of contamination on the items. We suggest that a 3-5 minute cycle be initiated and more time added if necessary.

Other applications of direct cleaning are pictured below:

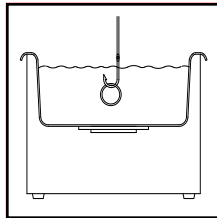

A ring suspended directly into the tank.

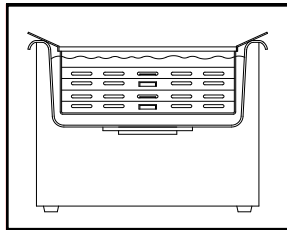

Instrument cassettes, held in a cassette rack and placed directly into the tank.

Indirect Method

When a cleaning application necessitates a series of different solutions, or when a specialized solution which is not to be placed directly into the tank is to be used, the following procedure is recommended.

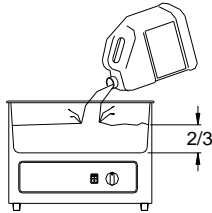

Fill the stainless steel tank approximately $\frac{2}{3}$ full with a proper **L&R** solution or carrier bath.

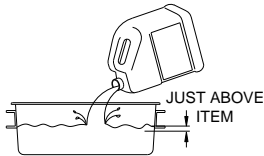

Fill auxiliary pan or beaker (s) with designated **L&R** cleaning solution(s) to a level just above the item(s) to be cleaned.

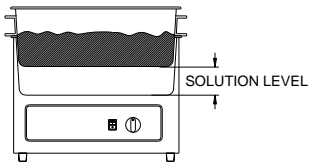

Place auxiliary pan into main tank, resting it on its handles, making sure that the bottom of the auxiliary pan is below the solution level in the main tank, add water if necessary. This insures proper sound wave transference.

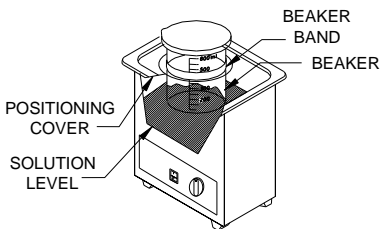

If a beaker or beakers are used, place the beaker in an L&R positioning cover using the beaker band to adjust the depth of the suspension so that the beaker bottom is slightly below the surface of the solution in the main tank, but off the bottom.

Popular Accessories

For Machine Type		Solid Side Draining Basket	Stainless Steel Mesh Basket	Auxiliary and Soak Pan
PC3		N/A	13329	N/A
90		N/A	11086	11032
140, 150R, 2014		10632	11088	10634
200	full size	18666	19103	19366
	¾ size	18670		
210		15154	10140	11093
255		17732	18652	17801
280		15155	10141	10636
310, 310R	full size	13518	N/A	N/A
	half size	18202	N/A	N/A
360, 360R		18676	N/A	12267
650, 650R	full size	17954	N/A	13102
	half size	17953	17739	17740
1000	full size	19620	N/A	N/A
	half size	19355	N/A	N/A

L&R supplies a full line of accessories for your Ultrasonic Cleaning System. Consult your dealer for more information or visit our web site at www.LRultrasonics.com.

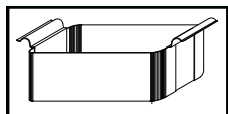

Solid Side Basket

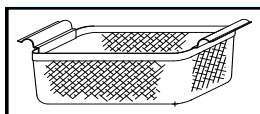

Mesh Basket

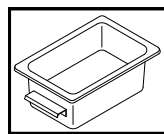

Auxiliary Pan

Ultrasonic Cleaning Solutions

L&R chemists have formulated a complete line of aqueous and non-aqueous based solutions to compliment our ultrasonic cleaning systems. Listed below are some of the common cleaning tasks and recommended L&R cleaning solutions.

Solutions / General Cleaning Applications			
L&R Solution	P/C	Qty	Soils/Substrate
SF-1	221	Gallon	Light oils and greases. Safe on metals, glass, plastic
SF-50	071	Gallon	Carbonaceous soils, heavy oils, greases
Hydrosonic Concentrate	201	Gallon	Fingerprints, oils, greases, lapping and buffing compounds
Hydrosonic Concentrate, non-ammoniated	110	Gallon	Same as above without ammonia
General Purpose Cleaner, ammoniated	226	Gallon	Buffing compounds, tripoli and rouge
#112 Instrument Cleaning Solution, ammoniated	188	Gallon	Gummed oils, greases, asphalt, tar, carbonized residues
#222 Instrument Cleaning Solution, non-ammoniated	191	Gallon	Same as above without ammoniate odor
Instrument Rinsing Solution	194	Gallon	Rinse after cleaning with #112, #222

Dental/Medical Cleaning Applications

Product	Product code	size	Description
UltraDose® Ultrasonic Cleaning Solution	UD012	24 x 1oz. tubes	Blood, debris, buffing compounds, soils, oxides, rouges & tripoli
UltraDose® Germicidal hospital grade Ultrasonic Cleaner Concentrate	UD036	16 oz.	Disinfects instruments, appliance, germicidal
General Purpose Cleaner Concentrate, non-ammoniated	228	Gallon	Dried blood, debris, foreign matter, buffing compounds
Tartar, Light Stain and Perm. Cement Remover	232	Gallon	Tartar & light stains, hard water scale
Advanced Formula Temporary Cement Remover	293	Gallon	Most temporary cements
Plaster and Stone Remover	230	Gallon	Plaster and stone
Evacuation Cleaner Concentrate	107	Gallon	Organic debris from evacuation lines
Barrier Milk Concentrate	076	Gallon	To protect instruments before autoclave from corrosion

Watch/Jewelry Cleaning Applications

Jewelry Cleaner Concentrate, ammoniated	170	Gallon	Dirt, soap, light oil, fingerprints
Prep Clean, BCR	078	Gallon	Buffing compounds, light oils, particulate soils
#111 Watch Cleaning Solution, Ammoniated	112	Gallon	Gummed oils, greases, sulfides
#566 Ultrasonic Watch Cleaning Solution, non-ammoniated	115	Gallon	Same as above without ammonia odor
#677 Ultrasonic Clock Cleaning Solution, non-ammoniated	135	Gallon	Same as above
#3 Watch Rinsing Solution	118	Gallon	Rinse after cleaning with #111, #566, #677

Weapon Cleaning Applications

Safety Ultrasonic Weapon Cleaning Solution Concentrate	215	Gallon	Carbonaceous soils and residues associated with weapons
Safety Weapon Lubricating Solution	212	Gallon	Displace water and primary lubricant

For more information please visit our web site at www.LRultrasonics.com.

Note: Most solutions listed above are also available in 55-gallon drums. Contact your dealer or the factory for ordering assistance.

Using safety glasses and gloves is recommended to safeguard against potential eye and skin injury or irritation.

Disposal of the solutions should be in accordance with local regulations.

Your Application Notes

Trouble Shooting

If your ultrasonic cleaner does not operate to your satisfaction, please consult the guide below before calling your authorized service center.

Cleaner will not start	<ul style="list-style-type: none"> • Cleaner not plugged in properly; • Timer not ON; • Timer Light Not on; • Blown fuse 	<p><i>Plug into a functioning electrical outlet;</i></p> <p><i>Turn timer clockwise</i></p> <p><i>Turn rear power switch ON</i></p> <p><i>Call authorized service center</i></p>
Cleaner operates but does not heat solution	<ul style="list-style-type: none"> • Heat switch not ON; • Heater malfunctions 	<p><i>Turn heat ON</i></p> <p><i>Call authorized service center</i></p>
Cleaner will not drain	<ul style="list-style-type: none"> • Clogged drain 	<p><i>Call nearest service center</i></p>
Decreased ultrasonic activity	<ul style="list-style-type: none"> • Solution is not degassed • Solution is dirty • Solution level is incorrect for the load • Tank bottom is covered with soil particles • Using de-ionized water in the tank 	<p><i>Make sure the tank was filled with warm tap water plus cleaning solution and has run 5 to 10 minutes</i></p> <p><i>Change solution</i></p> <p><i>Adjust solution level to one inch from the top of the tank with the load</i></p> <p><i>Empty, clean the tank with warm water and a non-abrasive cloth</i></p> <p><i>Do not use. De-ionized water does not cavitate as well a ultrasonic solutions.</i></p>

Foil Test

An aluminum foil test is a method to evaluate the general cleaning intensity and soundwave coverage throughout the tank. Perform this test as follows:

- Obtain any regular grade (not heavy duty) aluminum foil sold in a supermarket (less than 0.001 in. thick). Cut a piece large enough to cover $\frac{1}{2}$ to $\frac{3}{4}$ of your tank bottom.
- Fill the tank as usual with room temperature L&R General Purpose Cleaner Concentrate (L&R 012) or L&R Jewelry Cleaner Concentrate, diluted as specified.
- Run the machine for 10 minutes without a basket and with heat off, to de-gas the solution.
- Lower the foil into the operating tank vertically and centered to the bottom.
- Continue to hold the foil and let the machine run for one minute.
- Turn the machine off and remove the foil.
- Examine your piece of foil. There should be a peening effect and/or some perforations on the foil. The location and size of those peening or perforation patterns indicate the cleaning intensity and uniformity of the ultrasonic sound waves in the tank.

Service Center Locations

For International service, please contact your local distributor.

- A. Do not send covers or accessories with machine.
- B. When a warranty repair is requested, please include a copy of the invoice with the repair, showing the date of purchase.

California

Electronic Instrument Service
190 Deep Stone Dr.
San Rafael, CA 94903
Phone: 415-479-8960
Fax: 415-492-8565
Email: richwong@electronicinstrumentservice.com
Contact person: Richard Wong

New Jersey

L&R Manufacturing Co.
Foot of John Hay Ave.
Kearny, NJ 07032-0607
Phone: 201-991-5330
Fax: 201-991-5870
Email: repairs@LRultrasonics.com
Contact person: Eleanor Narozny

New York

S&E TV and Electronics
442 Niagara Falls Blvd.
Buffalo, NY 14223
Phone: 716-832-1595
Fax: 716-836-7329
Email: jewels@adelphia.net
Contact person: Jim Bastedo

Texas

Alpha Omega Ultrasonics
2821 National Dr.
Garland, TX 75041
Phone: 972-271-5569
Fax 972-840-3668
Email: jdnewman2@aol.com
Contact person: Jim Newman

International Service Centers

Australia

Intersonic Systems
9 Mapiti Place
Acacia Gardens NSW
Australia
Phone: 61 2 9837 3210
Fax: 61 2 9837 3298
Email: intersonic@bigpond.com
Contact person: Sam Granata

Belgium

Arseus
Textielstraat 24
B 8790 Waregem
Belgium
Phone: 32 56 62 88 66
Fax: 32 56 62 88 72
Email: Marleen.Cortvriend@arseus-tec.be
Contact person: Marleen Cortvriend

Canada

Electro Dental Services
6984 McPherson Ave.
Burnaby, B.C. Canada V5J 4N3
Phone: 604-439-0024
Fax: 604-439-1059
Email: tsemil@yahoo.com
Contact person: Tomas Soltesz

United Kingdom

Plandent
Unit 6, Argyle Ind. Estate
Fulton Close - Stevenage Herts SG12AF
United Kingdom
Phone: 44 14384385800
Fax: 44 1438 735801
Email: Fiona.cort@claudiusash.co.uk
Contact person: Fiona Cort

Crystal Electronics Inc.
2-1251 Gorham St.
Newmarket, Ontario, Canada L3Y 8Y6
Phone: 905-953-9129
Fax: 905-953-7965
Email: info@crystalelectronics.ca
Contact person: Terri Barber

C/N 85030 Rev. K